

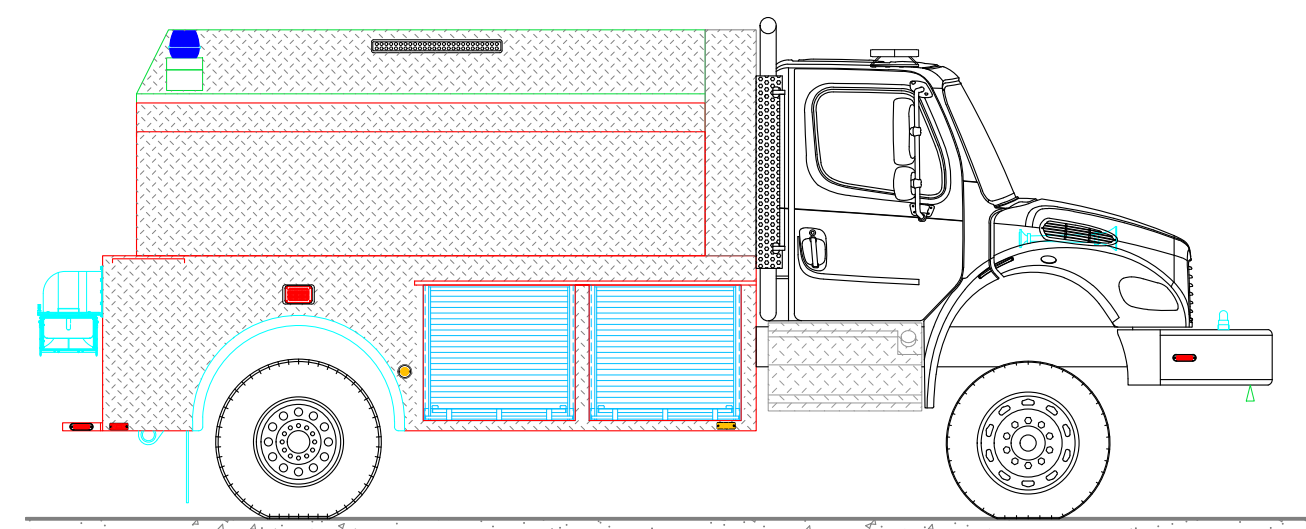
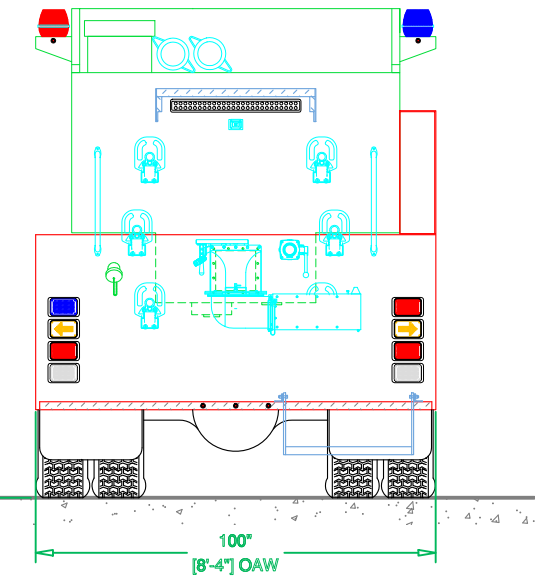
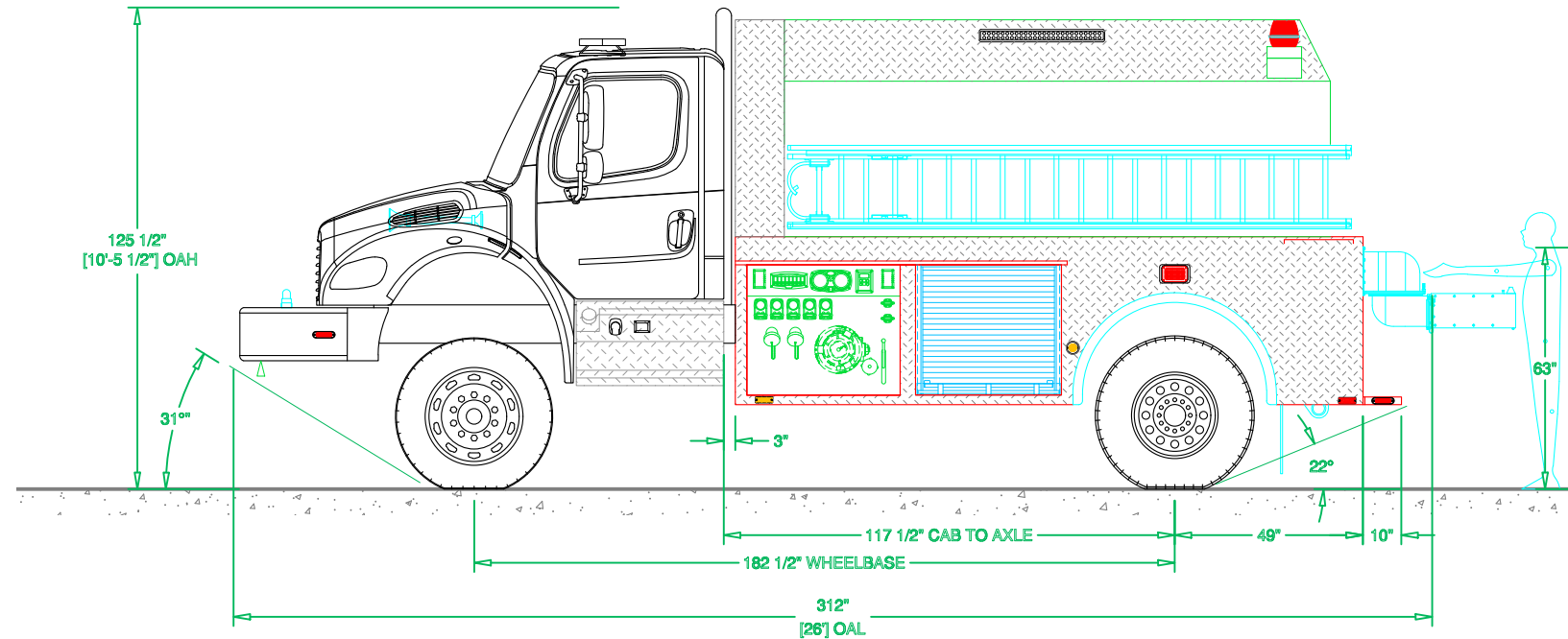
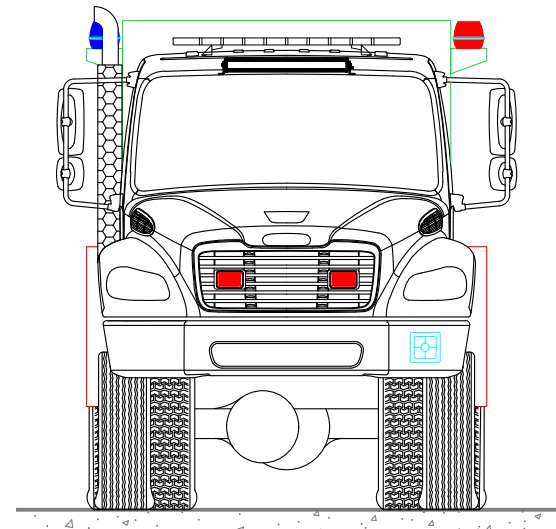
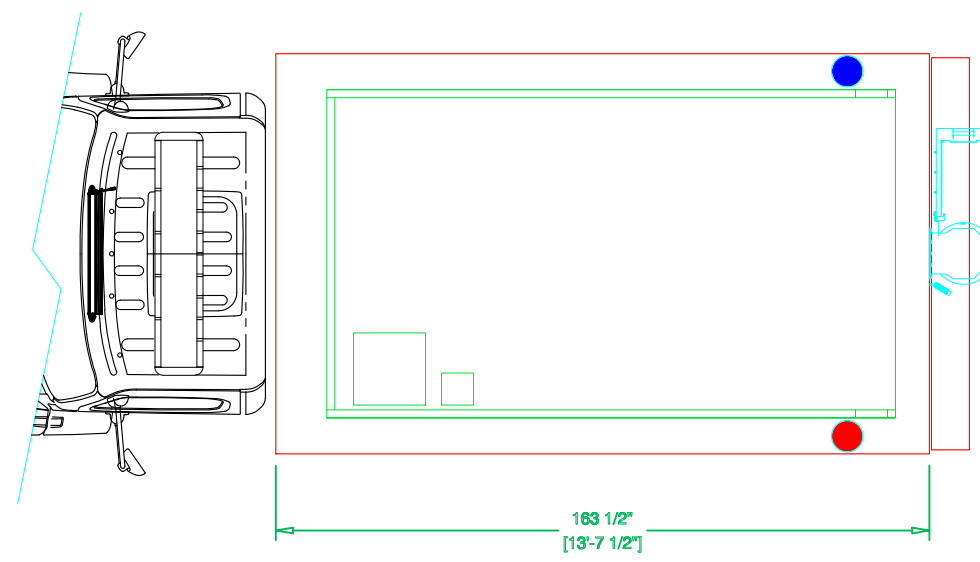

PRELIMINARY DRAWING - FOR LAYOUT PURPOSES ONLY

REVISIONS			
REV	DESCRIPTION	DATE	BY

NOTE 1: Do not scale drawing. This drawing is for general truck configuration only. All items and dimensions shown are approximate and may vary with final production. The drawing may not provide illustration for all items in the specification. In all situations where the drawing may contradict the specifications, the specifications shall prevail. This drawing and all data herein are provided as confidential materials and shall not be reproduced without written consent of the manufacturer.

NOTE 2: Chassis frame height will change due to axle characteristics, loading and tire dimensions which will affect the overall height dimension shown. Any overall height restrictions should take this into consideration and allow approximately 2-3 inches of tolerance.





SVI FIRE & RESCUE TRUCKS
3842 REDMAN DRIVE, FORT COLLINS, CO 80524 PHONE 970-297-7100, FAX 970-297-7099

**SW HWY 115
FIRE DEPARTMENT**

BODY SIZE: 14' BODY	UNIT TYPE: TANKER
BODY MATERIAL: 3/16" ALUMINUM	TRUCK NO: SVI #000
CHASSIS TYPE: FREIGHTLINER	WHEELBASE: SEE DWG
M2 - 106	CAB TO AXLE: 118.00
-	OVERALL LENGTH (OAL): SEE DWG
TWO DOOR	OVERALL WIDTH (OAW): 100.00
	OVERALL HEIGHT (OAH): SEE DWG

DRAWN BY: **---** DATE: **Oct. 6, 23** SCALE: **1/4" = 1'-0"**

DRAWING NO: **SWHWY115_CO_WS PreCon1** SHEET **1 OF 2**

PRELIMINARY DRAWING - FOR LAYOUT PURPOSES ONLY

REVISIONS			
REV	DESCRIPTION	DATE	BY

NOTE 1: Do not scale drawing. This drawing is for general truck configuration only. All items and dimensions shown are approximate and may vary with final production. The drawing may not provide illustration for all items in the specifications, the specifications shall prevail. This drawing and all data herein are provided as confidential materials and shall not be reproduced without written consent of the manufacturer.

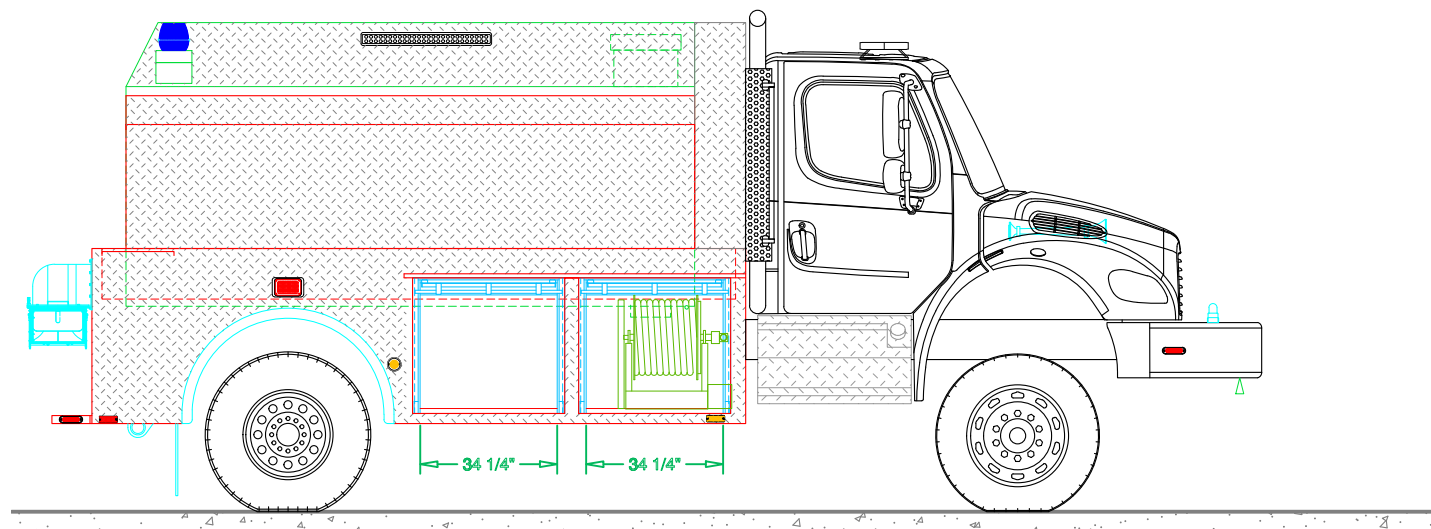
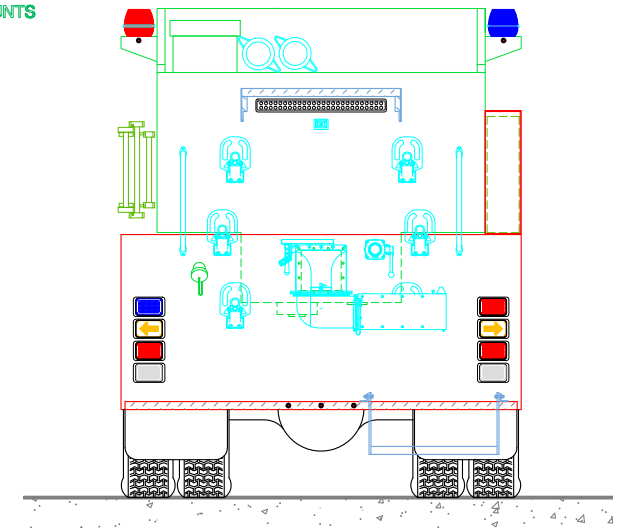
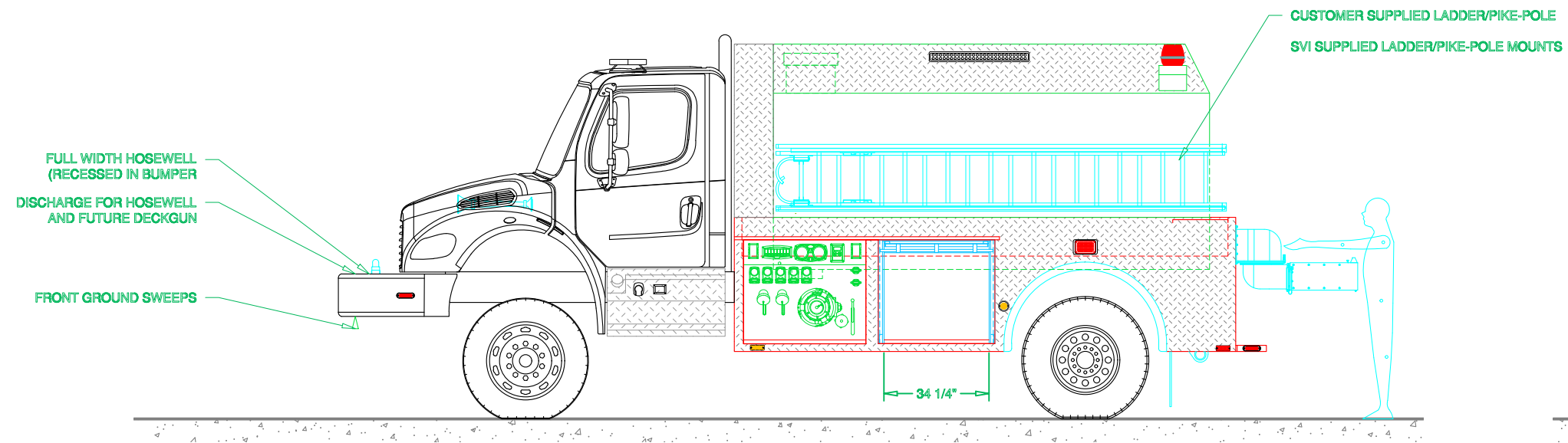
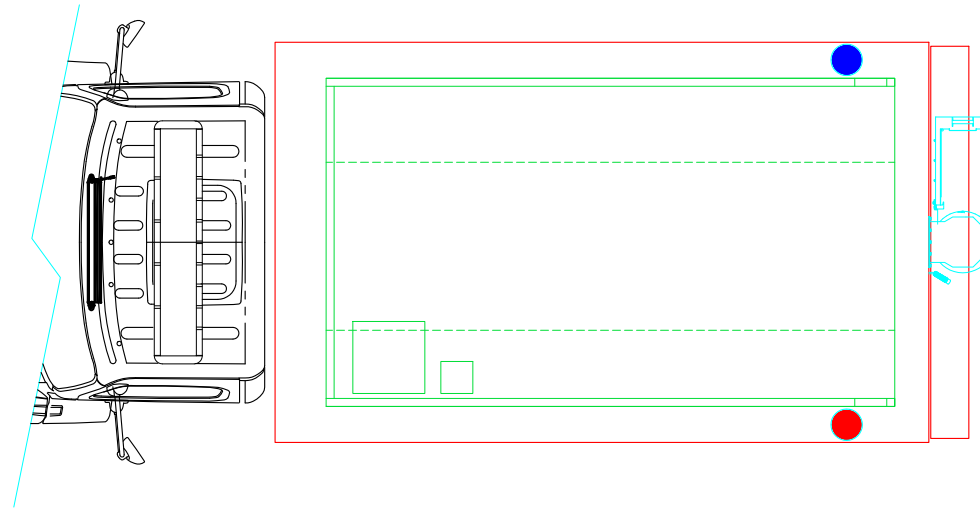



SVI FIRE & RESCUE TRUCKS
3842 REDMAN DRIVE, FORT COLLINS, CO 80524 PHONE 970-297-7100, FAX 970-297-7099

SW HWY 115
FIRE DEPARTMENT

DRAWN BY: —	DATE: Oct. 6, 23	SCALE: 1/4" = 1'-0"
DRAWING NO: SWHWY115_CO_WS PreCon1		SHEET 2 OF 2