



## Old Bridge Fire District 2, Old Bridge (NJ) Walk-Around Heavy Rescue #1247

### Chassis

Cab: Supthen Monarch SMFD  
Engine: Cummins L9 450 HP  
Transmission: Allison 4000 EVS  
Wheelbase: 237"

### Body

Material: Aluminum  
Body Length: 22'  
Overall Height: 11' - 0"  
Overall Length: 37' - 10"

### Features

Command Light CL Series Light Tower  
Lista Drawer Tool Cabinet  
Warn Zeon 8-S Electric Winch  
Onan 25 kW PTO Generator  
Walk-Up Rear Stairway  
OnScene Solutions Access PRO LED Lighting  
OnScene Solutions 84 Series Out-and-Down Cargo Slide  
OnScene Solutions 83 Series Transverse Cargo Slides  
Under-Stair Storage  
R • O • M Series IV Roll Up Doors

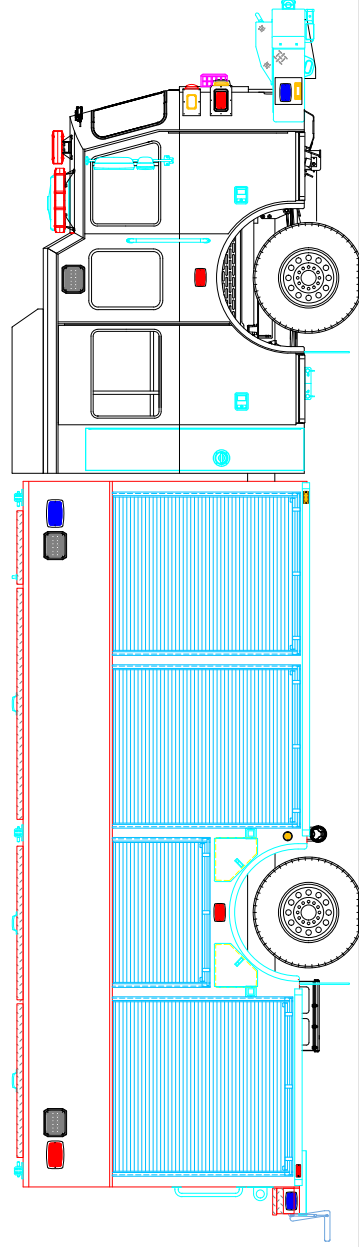
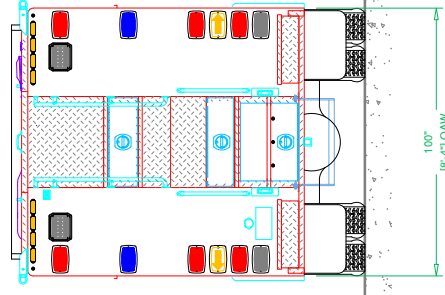
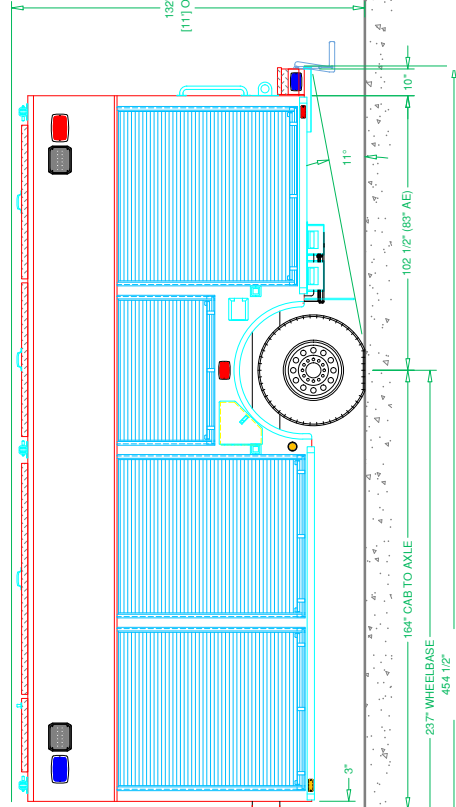
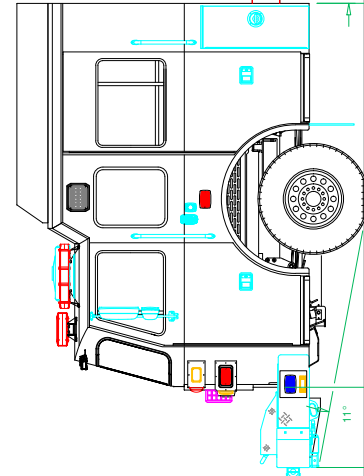
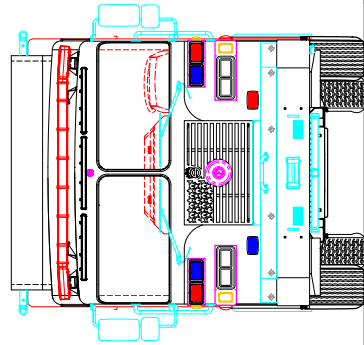
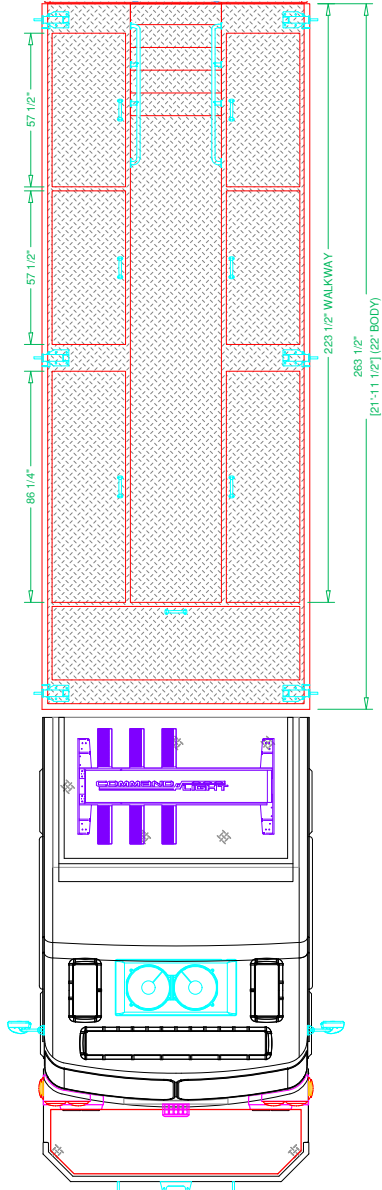

See more at [svitrucks.com](http://svitrucks.com)